

MEK2S Series

2W, Unregulated, 3KV Isolation, DC/DC Converters

Features

- ▶ Rated power: 2W max
- ▶ Input voltage range $\pm 10\%$
- ▶ Unregulated output
- ▶ High efficiency up to 90%
- ▶ Isolation voltage 3KVDC
- ▶ Small no load input current
- ▶ Operating temp. range: -40 ~ +105°C ambient
- ▶ RoHS compliant
- ▶ Compact SIP7 package
- ▶ Continuous short circuit protection
- ▶ Meet UL/EN/IEC 62368-1 EN 55032 Class B
- ▶ 5 year warranty

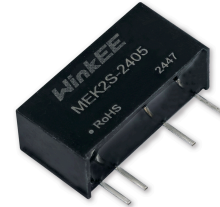

Overview

The MEK2S series are unregulated SIP7 package DC/DC converters with single or dual outputs, and 3KVDC isolation. These converters feature high efficiency, low ripple and noise, continuous short circuit protection, and wide operating temperature range. They are widely used in distributed power system in industrial applications where isolation and voltage converting is needed.

Model Numbers

Model Number	Input Voltage [VDC] $\pm 10\%$	Output Voltage [VDC]	Output Current [mA] Max.	Efficiency [%] Typ.	Capacitive Load [μ F] Max.
MEK2S-0303	3.3	3.3	400	77	2400
MEK2S-0305	3.3	5	400	79	2400
MEK2S-0309	3.3	9	222	80	1000
MEK2S-0312	3.3	12	167	81	820
MEK2S-0503	5	3.3	400	83	2400
MEK2S-0505	5	5	400	85	2400
MEK2S-0509	5	9	222	85	1000
MEK2S-0512	5	12	167	86	820
MEK2S-0515	5	15	133	87	680
MEK2S-0524	5	24	83	88	560
MEK2S-0503D	5	± 3.3	± 303	83	± 1000
MEK2S-0505D	5	± 5	± 200	85	± 1000
MEK2S-0509D	5	± 9	± 111	85	± 560
MEK2S-0512D	5	± 12	± 83	86	± 560
MEK2S-0515D	5	± 15	± 67	87	± 220
MEK2S-0524D	5	± 24	± 42	87	± 100
MEK2S-1203	12	3.3	400	84	2400
MEK2S-1205	12	5	400	85	2400
MEK2S-1209	12	9	222	86	1000

MEK2S Series

2W, Unregulated, 3KV Isolation, DC/DC Converters

Model Numbers

Model Number	Input Voltage [VDC]	Output Voltage [VDC]	Output Current [mA] Max.	Efficiency [%] Typ.	Capacitive Load [μ F] Max.
MEK2S-1212	12	12	167	87	820
MEK2S-1215	12	15	133	88	680
MEK2S-1224	12	24	83	89	560
MEK2S-1203D	12	± 3.3	± 303	84	± 1000
MEK2S-1205D	12	± 5	± 200	85	± 1000
MEK2S-1209D	12	± 9	± 111	86	± 560
MEK2S-1212D	12	± 12	± 83	87	± 560
MEK2S-1215D	12	± 15	± 67	88	± 220
MEK2S-1224D	12	± 24	± 42	86	± 100
MEK2S-1503	15	3.3	400	84	2400
MEK2S-1505	15	5	400	85	2400
MEK2S-1509	15	9	222	86	1000
MEK2S-1512	15	12	167	87	820
MEK2S-1515	15	15	133	88	680
MEK2S-1524	15	24	83	89	560
MEK2S-1505D	15	± 5	± 200	85	± 1000
MEK2S-1509D	15	± 9	± 111	86	± 560
MEK2S-1512D	15	± 12	± 83	87	± 560
MEK2S-1515D	15	± 15	± 67	88	± 220
MEK2S-2403	24	3.3	400	84	2400
MEK2S-2405	24	5	400	86	2400
MEK2S-2409	24	9	222	87	1000
MEK2S-2412	24	12	167	88	820
MEK2S-2415	24	15	133	89	680
MEK2S-2424	24	24	83	90	560
MEK2S-2403D	24	± 3.3	± 303	84	± 1000
MEK2S-2405D	24	± 5	± 200	86	± 1000
MEK2S-2409D	24	± 9	± 111	87	± 560
MEK2S-2412D	24	± 12	± 83	88	± 560
MEK2S-2415D	24	± 15	± 67	89	± 220
MEK2S-2424D	24	± 24	± 42	86	± 100

Electrical Specifications

Unless otherwise indicated, specifications are measured at $T_A=25^{\circ}\text{C}$, nominal input voltage, full load after warm up.

Parameters	Conditions	Min.	Typ.	Max.	Unit
Input current Full load	$V_{IN}=3.3\text{V}$		768		mA
	$V_{IN}=5\text{V}$		506		
	$V_{IN}=12\text{V}$	-	208	-	
	$V_{IN}=15\text{V}$		167		
	$V_{IN}=24\text{V}$		104		
Input current No load		-	4	15	mA
Reflected Ripple Current		-	15	-	mA
Surge voltage 1 second max	$V_{IN}=3.3\text{V}$	-0.7		5	VDC
	$V_{IN}=5\text{V}$	-0.7		9	
	$V_{IN}=12\text{V}$	-0.7	-	18	
	$V_{IN}=15\text{V}$	-0.7		21	
	$V_{IN}=24\text{V}$	-0.7		30	
Output voltage accuracy	All models	Refer to graphic in "Characteristic Curves" section			
Line regulation For V_{IN} change of $\pm 1\%$	$V_{OUT}=3.3\text{V}$	-	-	± 1.5	%
	All others			± 1.2	
Load regulation [2] $I_{OUT}=10\%$ to 100% of $I_{OUT, rated}$	$V_{OUT}=3.3\text{V}$		14		%
	$V_{OUT}=5\text{V}$		10		
	$V_{OUT}=9\text{V}$	-	9	-	
	$V_{OUT}=12\text{V}$		8		
	$V_{OUT}=15\text{V}$		7		
	$V_{OUT}=24\text{V}$		6		
Temperature coefficient	Full load	-	-	± 0.03	$\%/^{\circ}\text{C}$
Output ripple and noise	20MHz bandwidth	-	80	200	mVp-p
Output short circuit protection		Continuous, automatic recovery			
Input filter		Capacitor			
Hot plug		None			

Note [2]: Operating with less than 10% of rated load will not cause permanent damage to the converters, but the performances data may not fall into the specifications, and reliable operating is not assured. Dual output models need to operate with balanced load. The load difference between two outputs over 10% may cause unstable operating of the converter.

General Specifications

Parameters	Conditions	Min.	Typ.	Max.	Unit
Isolation voltage 1 minute, leakage current <1mA	Input to Output	3000	-	-	VDC
Isolation resistance Tested at 500VDC	Input to Output	1000	-	-	M ohm
Isolation capacitance 100KHz, 0.1V	Input to Output	-	20	-	pF
Switching frequency	Full load	-	220	-	KHz
Temperature rise at case	Full load	-	25	-	°C
Operating temperature	See "Derating Curve"	-40	-	+105	°C
Storage temperature		-55	-	+125	°C
Storage humidity	Non-condensing	5	-	95	%RH
Pin soldering resistance 1.5mm away from case for 10 sec		-	-	300	°C
Case material		Black plastic UL94-V0			
Cooling method		Free air convection			
Vibration		10-150Hz, 5G, 0.75mm along X, Y and Z			
MTBF	MIL-HDBK-217F	>3,500,000 Hours, T _A =25°C			
Safety standards		UL/EN/IEC 62368-1			
EMC standards	CISPR32, EN55032	Class B with "External Circuit"			
ESD	IEC/EN61000-4-2	Contact ±4kV, Air ±8kV, perf. Criteria B			
Size & Weight		19.65x7.05x10.16mm, 2.4g Typ.			

MEK2S Series

2W, Unregulated, 3KV Isolation, DC/DC Converters

Characteristic Curves

Output vs Ambient Temperature

All models

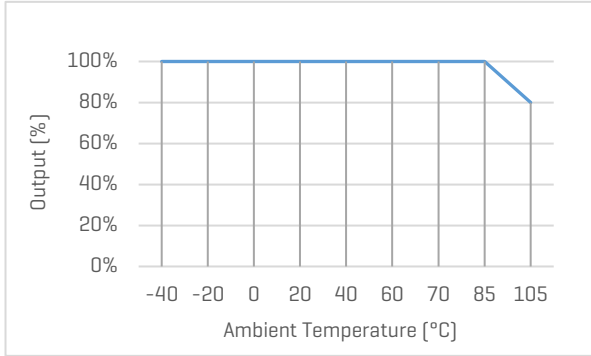

Output Voltage Accuracy vs Load

None 3.3V output models

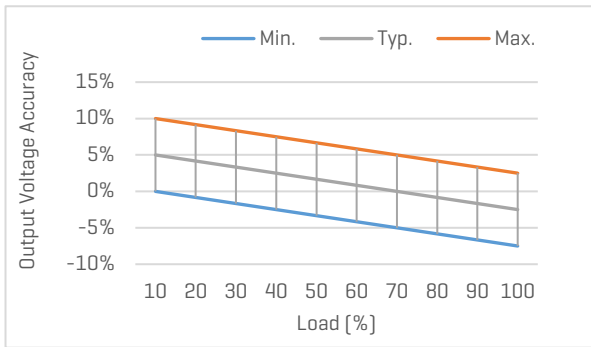

3.3V output models

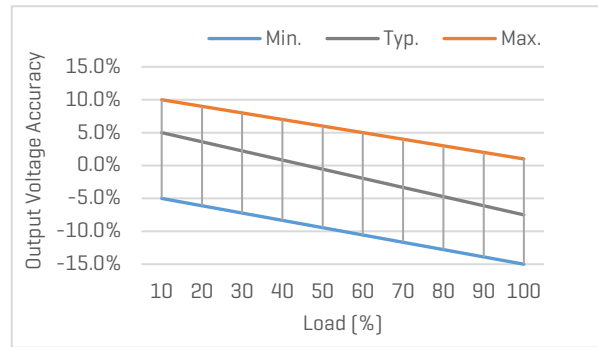

MEK2S Series

2W, Unregulated, 3KV Isolation, DC/DC Converters

Recommended External Circuit

Typical Application Circuit

*Typical application circuit is to further lower the input and output ripple. It is not mandatory.

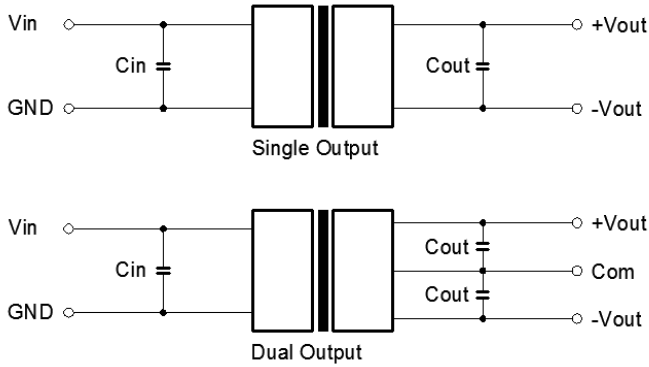

Figure 1. Typical external circuit

[Table 1] Recommended component spec

Input voltage	3.3, 5V	12V	15V	24V
C_{IN}	4.7uF, 16V	2.2uF, 25V	2.2uF, 25V	1uF, 50V

[Table 2] Recommended component spec

Single Out	3.3, 5V	9, 12V	15, 24V
C_{OUT}	10uF, 16V	2.2uF, 25V	1uF, 50V
Dual Out	$\pm 3.3, \pm 5V$	$\pm 9, \pm 12V$	$\pm 15, \pm 24V$
C_{OUT}	4.7uF, 16V	1uF, 25V	0.47uF, 50V

EMC Enhancement for EN55032 Class B

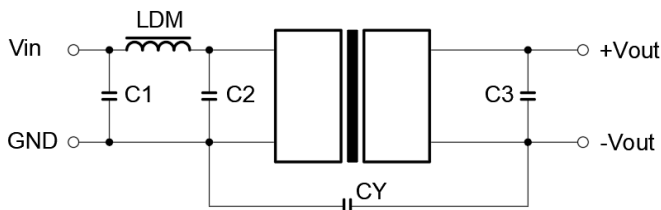

Figure 2. Circuit for EMC enhancement

[Table 3] Recommended component spec

Component	LDM	C1, C2	CY
C_{OUT}	6.8uH	4.7uF, 50V	1nF, 4KV

*"C3" refer to C_{OUT} in [Table 2]

Mechanical Specifications

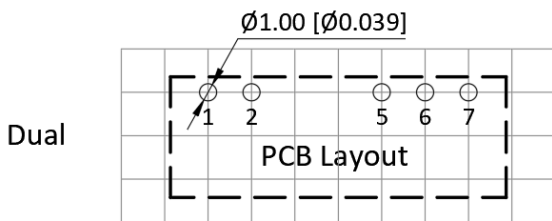
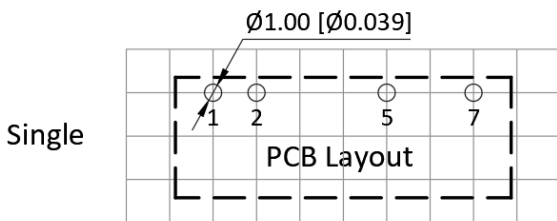
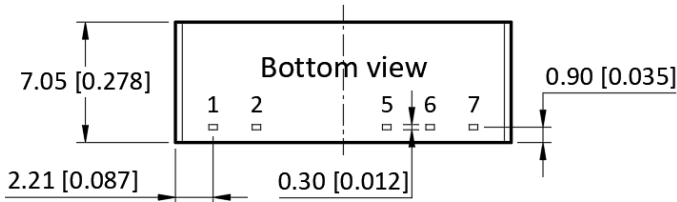
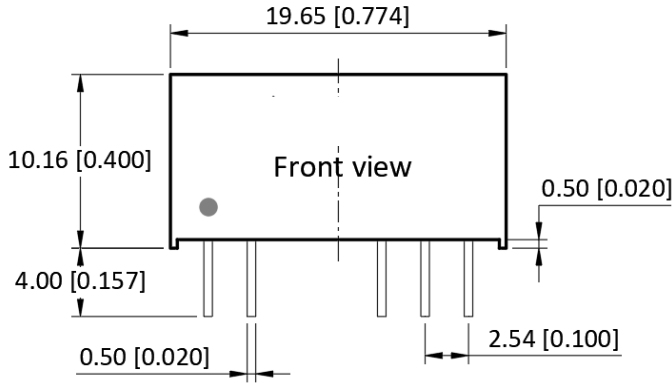

Pin Definition

Pin #	Single Out	Dual Out
1	+V _{IN}	+V _{IN}
2	-V _{IN}	-V _{IN}
5	-V _{OUT}	-V _{OUT}
6	No Pin	COM
7	+V _{OUT}	+V _{OUT}

* Unless otherwise specified unit: mm [inch]

* General tolerance: ±0.50 [±0.020]

* Pin thickness: ±0.10 [±0.004]

* Footprint grid 2.54 x 2.54 mm