

MWK1S Series

1W, Ultra-wide 8:1 Input Range, 3KV Isolation, SIP8 Package DC/DC Converters

Features

- ▶ Rated power: 1W Max
- ▶ Input voltage range: 4.5~36VDC [8:1]
- ▶ Regulated output
- ▶ High efficiency up to 74%
- ▶ Isolation voltage 3KVDC
- ▶ Operating temperature range: -40 ~ +85°C ambient
- ▶ RoHS compliant
- ▶ Compact SIP8 package
- ▶ Under voltage, over current and short circuit protection
- ▶ Meet UL/EN/IEC 62368-1 CISPR32, EN55032
- ▶ 5 year warranty



Overview

The MWK1S series are 3KV isolated 1Watt DC/DC converters with compact SIP8 footprint. Designed with high efficiency, they operate in a wide temperature range from -40°C to +85°C. Other features include wide 8:1 ultra-wide input voltage range, under voltage, over current and short circuit protections. These converters are ideally suitable for battery operated equipment, measurement equipment, telecom, wireless network, industrial control system.

Model Numbers

Model Number	Input Voltage [VDC]			V _{OUT} [VDC]	Output Current [mA]		Efficiency [%] Typ.	Capacitive Load [uF] Max.
	Nominal	Range	*Max.		Max.	Min.		
MWK1S-1205	12	4.5~36	40	5	200	0	71	470
MWK1S-1209	12	4.5~36	40	9	111	0	72	220
MWK1S-1212	12	4.5~36	40	12	83	0	74	220
MWK1S-1215	12	4.5~36	40	15	67	0	74	220
MWK1S-1224	12	4.5~36	40	24	42	0	74	220
MWK1S-1205D	12	4.5~36	40	±5	±100	0	71	±220
MWK1S-1212D	12	4.5~36	40	±12	±42	0	74	±150
MWK1S-1215D	12	4.5~36	40	±15	±33	0	74	±68

* Only typical models are listed. Other models may be available upon request.

* Input voltage exceed the Max. value may cause permanent damage.

Electrical Specifications

Unless otherwise indicated, specifications are measured at $T_A=25^{\circ}\text{C}$, nominal input voltage, full load after warm up.

Parameters	Conditions	Min.	Typ.	Max.	Unit	Note
Input current Full load		-	116	-	mA	
Input current No load		-	10	-	mA	
Input reflected ripple current		-	50	-	mA	
Input voltage surge 1 second max		-0.7	-	50	Vdc	
Startup input voltage		-	-	4.5	Vdc	
Input under voltage shutdown		2.5	3.5	-	VDC	
Output voltage accuracy	Main output Other output	-	± 1 ± 3	± 3 ± 5	%	
Line regulation Full load, $V_{IN} = V_{IN, Min}$ to $V_{IN, Max}$	Main output Other output	-	-	± 0.5 ± 1.0	%	
Load regulation $I_{OUT}=5\%$ to 100% of $I_{OUT, rated}$	Main output Other output	-	-	± 1.0 ± 1.5	%	
Output ripple and noise 20MHz bandwidth, peak to peak		-	60	100	mVp-p	
Temperature coefficient	Full load	-	-	± 0.03	%/ $^{\circ}\text{C}$	
Dynamic load response $I_{OUT}=25\% \sim 50\% \sim 75\%$ of $I_{OUT, rated}$	Peak deviation* Peak deviation Recovery time	-	± 5 ± 3 0.3	± 8 ± 5 0.5	% V_{OUT} % V_{OUT} mS	* $V_{OUT}=5, \pm 5\text{V}$
Output over current protection		110	-	300	% I_{OUT}	
Output short circuit protection		Continuous, automatic recovery				
Input filter		Capacitive				
Hot plug		None				

* Operating with less than 5% of rated load will not cause damage to the converters, but the performances data may not fall into the specifications, and stable operating is not assured.

General Specifications

Parameters	Conditions	Min.	Typ.	Max.	Unit	Note
Isolation voltage 1 minute, leakage current 1mA max.	Input to Output	3000	-	-	VDC	
Isolation resistance Tested at 500VDC	Input to Output	1000	-	-	M ohm	
Isolation capacitance 100KHz, 0.1V	Input to Output	-	40	-	pF	
Switching frequency	Full load	-	300	-	KHz	PWM mode
Operating temperature	No derating	-40	-	+85	°C	
Storage temperature		-55	-	+125	°C	
Storage humidity	None condensing	5	-	95	%RH	
Pin soldering resistance 1.5mm away from case for 10 sec		-	-	300	°C	
Case material		Black plastic UL94-V0				
Cooling method		Free air convection				
Vibration		10-150Hz, 5G, 0.75mm along X, Y and Z				
MTBF	MIL-HDBK-217F	>1,000,000 Hours, T _A =25°C				
Design based on standards		IEC/EN/UL 62368-1				
Safety certifications		IEC/EN 62368-1				
EMC	Emission Immunity	CISPR32, EN55032 Class B with external circuit IEC/EN61000-4-2, 3, 4, 5, 6				
Size & Weight		22x9.5x12mm, 4.5g				

*External circuit is required in order to meet Class B, refer to Figure 2 in Recommended External Circuit

Characteristic Curves

Derating Curve

Output vs Ambient Temperature

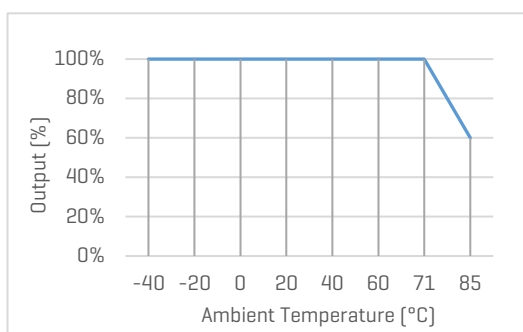

MWK1S Series

1W, Ultra-wide 8:1 Input Range, 3KV Isolation, SIP8 Package DC/DC Converters

Recommended Application Circuit

Typical Application Circuit

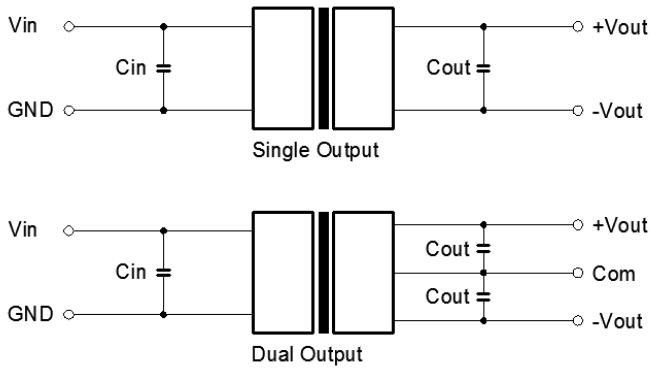

Note

*Typical application circuit is to further lower the input and output ripple. It is not required for general use.

*Recommended component specifications are typical values. Excessive external capacitive load may cause startup problem.

[Table 1] Recommended component spec

C_{IN}	100uF, 50V
C_{OUT}	22uF, 50V

Figure 1. Typical External Circuit

EMC Enhancement for EN55032 Class B

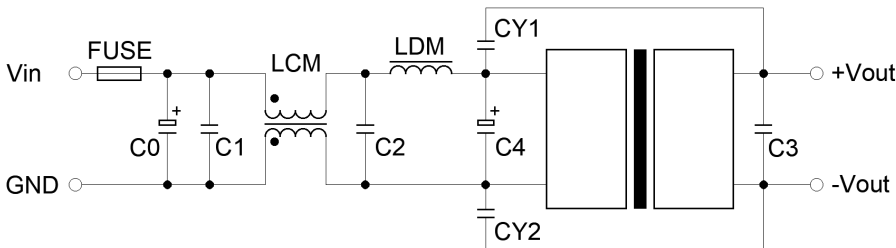

Figure 2. Circuit for EMC Enhancement

Recommended component spec

Items	C0	C1, C2	C3	C4	LCM	LDM	CY1, CY2
Spec	1000uF, 50V	4.7uF, 50V	22uF, 50V	100uF, 50V	2.2mH	4.7uH	1nF, 3KV

*FUSE to be selected according to application needs.

MWK1S Series

1W, Ultra-wide 8:1 Input Range, 3KV Isolation, SIP8 Package DC/DC Converters

Mechanical Specifications

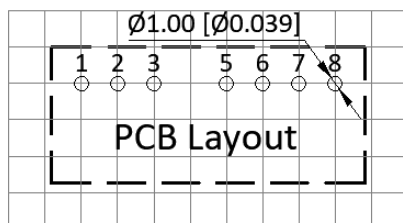
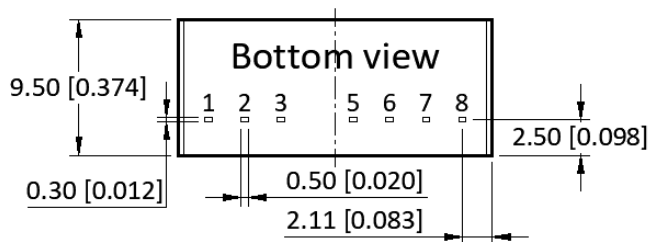
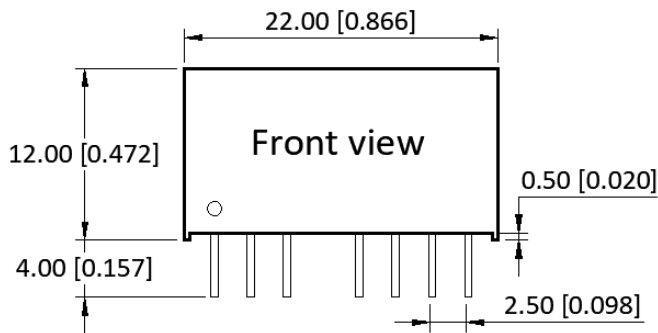

Pin Definition

Pin #	Single Out	Dual Out
1	GND	GND
2	V _{IN}	V _{IN}
3	NC	NC
5	NC	NC
6	+V _{OUT}	+V _{OUT}
7	OV	COM
8	NC	-V _{OUT}

* Unless otherwise specified unit: mm [inch]

* General tolerance: ± 0.50 [± 0.020]

* Pin thickness: ± 0.10 [± 0.004]

* Footprint grid 2.54 x 2.54 mm

Copyright @ WinKEE Limited. All rights reserved. WinKEE reserves the right to make changes to the product at any time without notice. Information provided by WinKEE is believed to be accurate and reliable. However, no responsibility is assumed by WinKEE for its use, nor for any infringements of patents or other rights of third parties which may result from its use.